

# Calculation of Mass Transfer and Power Loss in a Nanofluidic Circuit



Yongbin Zhang\*

Changzhou University, China

Submission: April 01, 2018; Published: April 24, 2018

\*Corresponding author: Yongbin Zhang, College of Mechanical Engineering, Changzhou University, China, Email: engmech1@sina.com

## Abstract

The methods for calculating the mass/volume flow rate and the power loss in a nanofluidic circuit are shown, by using the concept of the flow resistance. In a nanofluidic circuit, there may be a lot of branches and may be involved the nanopump or/and the nanovalve. The exemplary analysis shows that in such a nanofluidic circuit, the mass/volume flow rate and the power loss can be easily calculated, by using the derived equations.

**Keywords:** Nanochannel; Nanofluidics; Circuits; Nanotube; Nanopump; Nanovalve

## Introduction

Experiments on nanofluidics have been done plentifully [1-4]. Fabrication of nanochannel and inventions of nano pump and nano valve have been in fast progress [5-10]. Nanofluidics have their special applications in transportation, purification, drug delivery, chemical analysis, DNA analysis and battery [11,12]. Nanochannel flow shows its special phenomena governed by the dynamic, non-continuum and interfacial slippage effects of the confined film, not obeying conventional fluid mechanics [13-16]. This makes the theoretical evaluation of the performance of nanofluidics quite challenging. It has been supposed that nanofluidic circuits can be fabricated as like electric circuits [17,18]. They can even be developed into an integrated system on a small size. This would greatly propel the application of nanofluidics. Karnik et al. [18] experimentally found that by applying the gate voltage, the flow of protein in nanochannel can be turned on or turned off. This function is undoubtedly important for nanofluidic circuits.

Analytical methods must be developed for nanofluidic circuits, which should not be limited to experimental fabrication. However, realization of this purpose is not easy since the study on nanochannel flow has mainly relied on numerical simulations like molecular dynamics simulation, the lattice Boltzmann simulation, the dissipative particle dynamics simulation and the multiscale hybrid simulation [19-22]. For the Poiseuille flow occurring in the cylindrical nanotube shown in Figure 1, in the absence of the fluid-wall interfacial slippage, the flow equation has been proposed as follows [23]:

$$q_m = \frac{\pi \rho_{bf}^{eff}(\bar{R}) |S(\bar{R})| R^4 \Delta p}{4 \eta_{bf}^{eff}(\bar{R}) l} \dots\dots (1)$$

where  $q_m$  is the mass flow rate through the tube,  $l$  is the length of the section of the nanotube,  $\Delta p$  is the pressure drop along the length  $l$  of the nanotube,  $R$  is the inner radius of the nanotube,  $\rho_{bf}^{eff}$  and  $\eta_{bf}^{eff}$  are respectively the average density and the effective viscosity of the confined fluid across the tube radius,  $S$  is the parameter depicting the non-continuum effect of the confined fluid across the tube radius ( $-1 \leq S < 0$ ),  $\bar{R} = R/R_c$ , and  $R_c$  is the critical inner radius of the tube for the fluid to become continuum across the tube radius. Equation (1) is valid for a simple fluid flow in a nanotube [23]. Regarding ionic flows, the validity of Equation (1) needs to be further verified; It might still stand by just modifying the rheological parameters  $\eta_{bf}^{eff}$ ,  $\rho_{bf}^{eff}$  and  $S$  [24]. The mass flow resistance was ever proposed by Alibakhshi et al [25]. Here, the flow resistance of the section of the nanotube in Figure 1a is defined as [26]:

$$i_f = \frac{\Delta p}{q_m} = \frac{4 \eta_{bf}^{eff}(\bar{R}) l}{\pi \rho_{bf}^{eff}(\bar{R}) |S(\bar{R})| R^4} \dots\dots (2)$$

The section of the nanotube in Figure 1 can thus just be simplified as the flow resistance with the value as shown in Figure 1.

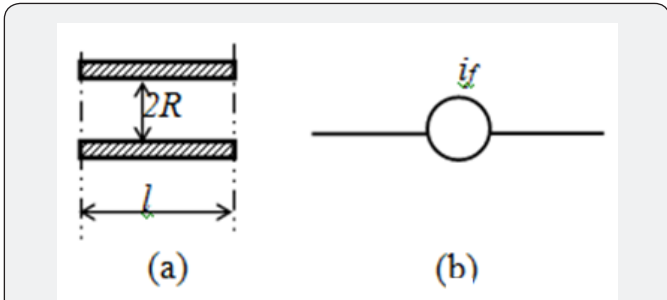

**Figure 1:** a) A section of the cylindrical nanotube with the inner radius  $R$  and the length  $l$ ; (b) The simplified expression of the nanotube in (a) in a nanofluidic circuit with the flow resistance  $i_f$  [26].

Two flow resistances  $i_{f,1}$  and  $i_{f,2}$  can be in series connection or in parallel connection as shown in Figure 2. In whichever connection, they can also be simplified into one flow resistance with the value  $i_f$  as shown in Figure 1. For the series connection,  $i_f$  is [26]:

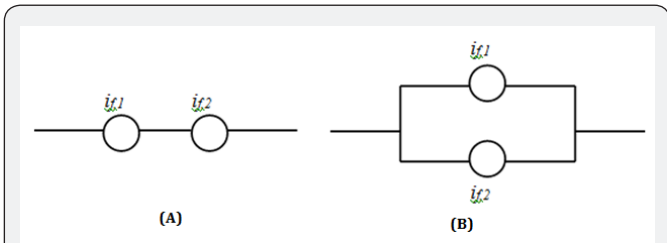

**Figure 2:** (a) Two flow resistances in series connection; (b) Two flow resistances in parallel connection.

$$i_f = i_{f,1} + i_{f,2} \dots (3)$$

For the parallel connection,  $i_f$  is [26]:

$$i_f = \frac{i_{f,1} i_{f,2}}{i_{f,1} + i_{f,2}} \dots (4)$$

The power loss on the flow resistance in Figure 1 is [26]:

$$pow = \Delta p \cdot q_v \dots (5)$$

where  $\Delta p$  and  $q_v$  are respectively the pressure drop on and the volume flow rate through the flow resistance. Equation (5) can become [26]:

$$pow = \frac{\Delta p^2}{\rho_{bf}^{eff} i_f} = i_f q_v^2 \rho_{bf}^{eff} \dots (6)$$

Equations (2)-(6) are like those in electric circuits. They can be used for analysis of a nanofluidic circuit. Figure 3 shows the flow resistance with the value  $i_f$  and the nano pump with the power  $pow_M$  in parallel connection. The pressure drop on both of them is  $p_A$ . The volume flow rates through the two branch circuits and the main circuit are respectively:

$$q_{v,1} = \frac{p_A}{i_f \rho_{bf}^{eff}}, q_{v,2} = \frac{pow_M}{p_A}, q_v = q_{v,1} + q_{v,2} \dots (7)$$

The power loss on the whole circuits in Figure 3 is  $p_A \cdot q_v$ .

Figure 3 A nanofluidic circuit where the flow resistance ( $i_f$ ) is in parallel connection with the nano pump.

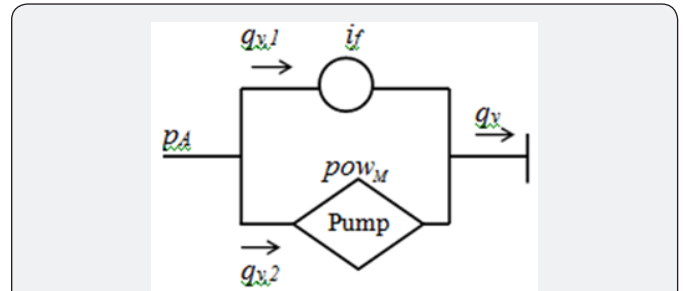
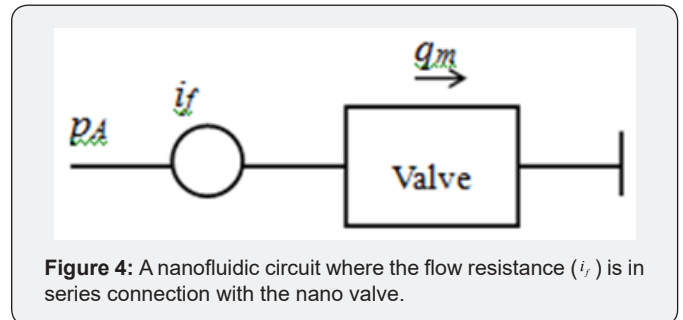

**Figure 3:** A nanofluidic circuit where the flow resistance ( $i_f$ ) is in parallel connection with the nano pump.

Figure 4 shows the flow resistance with the value  $i_f$  and the nano valve with the constant mass flow rate  $q_m$  in series connection. The power losses on the flow resistance and the nano valve are respectively:

$$pow_1 = \frac{i_f q_m^2}{\rho_{bf}^{eff}}, pow_2 = \frac{p_A q_m}{\rho_{bf}^{eff}} - pow_1 \dots (8)$$

Figure 4 A nanofluidic circuit where the flow resistance ( $i_f$ ) is in series connection with the nano valve.



**Figure 4:** A nanofluidic circuit where the flow resistance ( $i_f$ ) is in series connection with the nano valve.

**Conclusion**

In a conclusion, this paper presents the methods for calculating the mass/volume flow rate and the power loss in a nanofluidic circuit, by introducing the concept of the flow resistance. The derived equations for calculating these parameters are like those in electric circuits. The exemplary analysis shows that these equations can be easily implemented for calculating the corresponding performance parameters in a nanofluidic circuit.

**References**

1. Plecis A, Schoch RB, Renaud P (2005) Ionic transport phenomena in nanofluidics: Experimental and theoretical study of the exclusion-enrichment effect on a chip. Nano Lett 5(6): 1147-1155.
2. Berg AVD, Wessling M (2007) Nanofluidics: Silicon for the perfect membrane. Nature 445(7129): 726.
3. Goldberger J, Fan R, Yang P (2006) Inorganic nanotubes: A novel platform for nanofluidics. Acc Chem Res 39(4): 239-248.

- Wang S, Lee LJ (2012) Micro-/nanofluidics based cell electroporation. *Biomicrofluidics* 7(1): 011301.
- Guo LJ, Cheng X, Chou C (2004) Fabrication of size-controllable nanofluidics channels by nanoimprinting and its applications for DNA stretching. *Nano Lett* 4(1): 69-73.
- Zaidi SH, Brueck SRJ (1999) Interferometric lithography for nanoscale fabrication. *Proc SPIE* 3618(1): 2-8.
- Wei C (2007) Implantable nano pump for drug delivery, US Patent App 11/906,238.
- Ahn DJ (2008) Nano pump using molecular motor, US Patent App. 12/200,888(2008).
- Yu M, Falconer JL, Amundsen TJ, Hong M, Noble RD (2007) A controllable nanometer-sized valve. *Adv Mater* 19(11): 3032-3036.
- Bojko A, Andreatta G, Montagne F, Renaud P, Pugin R (2014) Fabrication of thermo-responsive nano-valve by grafting-to in melt of poly(N-isopropylacrylamide) onto nanoporous silicon nitride membranes, *J Membr Sci* 468(2014): 118-125.
- Piruska M, Gong JV, Sweedler JV, Bohn PW (2010) Nanofluidics in chemical analysis. *Chem Soc Rev* 39(2010): 1060-1072.
- Perry JL, Kandlikar SG (2006) Review of fabrication of nanochannels for single phase liquid flow, *Microfluid. Nanofluid* 2(2006): 185-193.
- Somers SA, Davis HT (1992) Microscopic dynamics of fluids confined between smooth and atomically structured solid surfaces. *J Chem Phys* 96(1992): 5389-5407.
- Jabbarzadeh A, Atkinson JD, Tanner RI (1997) Rheological properties of thin liquid films by molecular dynamics simulations. *J Non-Newtonian Fluid Mech* 69(1997): 169-193.
- Takaba H, Onumata Y, Nakao S (2017) Molecular simulation of pressure-driven fluid flow in nanoporous membranes. *J Chem Phys* 127(2007): 054703.
- Sofos F, Karakasidis TE, Liakopoulos A (2013) Parameters affecting the slip length at the nanoscale. *J Comput Theor Nanosci* 10(2013):648-650.
- Aguillela VM, Alcaraz A (2009) Nanobiotechnology: A fluid approach to simple circuits. *Nat Nanotech* 4(2009): 403-404.
- Karnik R, Castelino K, Majumdar A (2006) Field-effect control of protein transport in a nanofluidic transistor circuit. *Appl Phys Lett* 88(2006): 123114.
- Stillinger FH, Rahman A (1974) Improved simulation of liquid water by molecular dynamics. *J Chem Phys* 60(1974): 1545-1550.
- Hartings J, Kunert C, Hyvaluoma J (2009) Lattice Boltzmann simulations in microfluidics: probing the no-slip boundary condition in hydrophobic, rough, and surface nanobubble laden microchannels. *Microfluid Nanofluid* 8(2009): 1-11.
- Kasiteropoulou D, Karakasidis TE, Liakopoulos A (2011) Dissipative particle dynamics investigation of parameters affecting planar nanochannel flows. *Materials Sci Eng* 176(2011): 1574-1579.
- Yen TH, Soong CY, Tzeng PY (2007) Hybrid molecular dynamics-continuum simulation for nano/mesoscale channel flows. *Microfluid Nanofluid* 3(2007): 665-675.
- Zhang BY (2016) The flow equation for a nanoscale fluid flow. *Int J Heat Mass Transfer* 92(2016): 1004-1008.
- Han ZH, Yu SF, Pey KL, Ostrikov K (2013) Carbon nanotube membranes with ultrahigh specific adsorption capacity for water desalination and purification. *Nat Commun* 4(2013): 1-8.
- Alibakhshi MA, Xie Q, Li Y, Duan C (2006) Accurate measurement of liquid transport through nanoscale conduits. *Sci Rep* 6(2016): 24936.
- Zhang YB (2017) A design method for nanofluidic circuits.



This work is licensed under Creative Commons Attribution 4.0 License  
DOI: [10.19080/GJN.2018.04.555630](https://doi.org/10.19080/GJN.2018.04.555630)

**Your next submission with JuniperPublishers  
will reach you the below assets**

- Quality Editorial service
- Swift Peer Review
- Reprints availability
- E-prints Service
- Manuscript Podcast for convenient understanding
- Global attainment for your research
- Manuscript accessibility in different formats  
( Pdf, E-pub, Full Text, Audio)
- Unceasing customer service

Track the below URL for one-step submission

<https://juniperpublishers.com/submit-manuscript.php>